

Leseprobe

Christiani

Technical Institute for
Vocational Training

Basic Principles of Pneumatics

Course 3



Dr.-Ing. Paul Christiani GmbH & Co. KG
www.christiani.de

.....
Table of contents
.....

3

Preface

Advanced pneumatics

Certain laws of physics must be observed to enable compressed air to be used as a means of control and propulsion. This knowledge forms the basis of the functional principles and requirements of pneumatics.

1

Proportional pneumatics

Systems are subject to either open-loop or closed-loop control. It is the job of closed-loop control technology to bring specific variables such as temperature, speed, pressure, etc. to the prescribed value. This sometimes involves purely pneumatic processes, but often also includes electro-pneumatics, such as the use of proportional valves.

2

Vacuum technology

Vacuum technology is used in cases where parts are difficult or impossible to take hold of mechanically. Certain physical principles are important in this respect too. This chapter explains how a vacuum is generated and monitored and describes the different sizes and materials that are available for suction cups.

3

Link between pneumatics and electronics

Pneumatics is becoming increasingly integrated with electronics and links are being formed between the two technologies. Bus systems play a key role when it comes to incorporating pneumatics and electronics in a control system.

4

Index

5

.....
Preface
.....

5

In industrial automation, there are all kinds of systems and components at work: mechanical, electrical, hydraulic and pneumatic elements are all used to generate motion and force in most cases. Thanks to their simplicity, value for money and excellent reliability – as well as the fact that they have hardly any impact on the environment – pneumatics have really taken hold, and can now be found in virtually every branch of industry. New industrial sectors with a focus on advanced techniques are where most pneumatic technology is found, although it also has a presence in long-established fields such as machine tools, the food industry, the automotive industry and the electrical industry. Semiconductors and integrated circuits are two examples of recent developments that pneumatics have been involved in: the technology is used in all the manufacturing stages of these components. Industry requirements in this area are growing and changing rapidly all the time, which means that SMC in turn is continually developing new components to accommodate this.

The aim of this coursebook is to convey to the reader how the different topics are linked but without discussing the mathematical relationships in detail. This publication is targeted at a wide readership (e.g. skilled workers, technicians, engineers, etc.). Once they have completed the coursebook, they will have the knowledge required to design a simple vacuum and pneumatics system. What's more, this course will look at the basic concepts of closed-loop and open-loop control technology but without considering the complicated mathematical calculations.

Given the lighting rate at which microprocessor technology is progressing, it is essential that we are always seeking out ways to broaden and enhance our understanding and knowledge of how pneumatics and electronics can interact with each other. With respect to sensors, control systems (PLCs, etc.) and bus systems in particular, major technological progress has been made in the last few years. In order to create a basis for decision-making, this coursebook provides an overview of how electronic components in industrial automation can be integrated with pneumatics.

Weisslingen, Switzerland 30th January 2012

The authors

Ronny Balmer, SMC Pneumatik AG, Weisslingen, Switzerland
Marc Schultheiss, SMC Pneumatik AG, Weisslingen, Switzerland
Kurt Meier, M+S Industrielle Automation AG, Winterthur, Switzerland

1. Advanced pneumatics

15

The critical pressure ratio b can be calculated with the aid of the conductance C and any measuring point in the subcritical range.

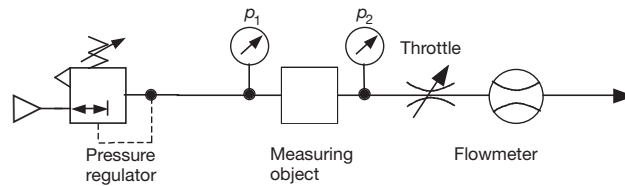

Fig. 1.4: Measuring configuration according to ISO 6358-1989, JIS B 8390-2000 (simplified)

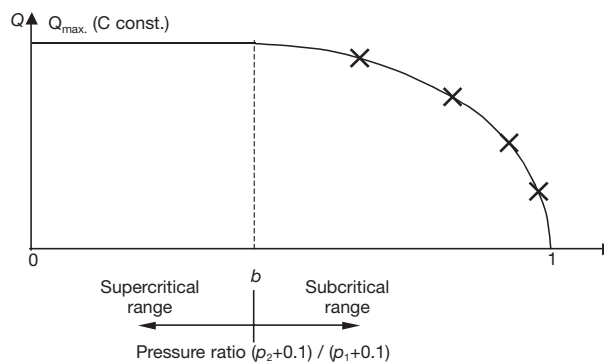

Fig. 1.5: Flow function subject to the pressure ratio

The flow can be calculated with the aid of the critical pressure ratio b and the conductance C at any point in the subcritical range.

If the b value is known, the supercritical flow range can be determined with the aid of a simple formula.

Example: For a valve, a b value of 0.36 and an inlet pressure of 0.6 MPa (p_1) are specified. At what pressure (p_2) is the supercritical flow range (sonic velocity) reached?

Supercritical flow range

$$b = \frac{p_2 + 0.1}{p_1 + 0.1}$$

$$p_2 = b \cdot (p_1 + 0.1) - 0.1$$

$$p_2 = 0.36 \cdot (0.6 + 0.1) - 0.1$$

$$p_2 = 0.152 \text{ MPa}$$

2.2 Positioners

2.2.1 Basics

Nozzle/flapper system

Controlling
 element of a
 control unit

The core element of certain positioners is the nozzle/flapper system. This forms part of the controlling element of a control unit. As shown in Fig. 2.12, the compressed air in p_2 is proportional to the air gap distance g between the flapper and nozzle, however only in a range specified by the manufacturer. The flapper influences the air gap by means of a reference variable (pressure, temperature or electrical signal). A large air gap means a low pressure in p_2 . If there is no air gap, the inlet pressure p_1 corresponds to the outlet pressure p_2 . The task is now to determine the optimum range of the gap during the development of a positioner.

The pressure from p_2 is processed further in the actuator, for example to move a flap via a rotary actuator. The nozzle/flapper system demonstrates a constant level of internal air consumption, which is not recommended when working with inert gases as well as with very low pressures (up to 0.005 MPa).

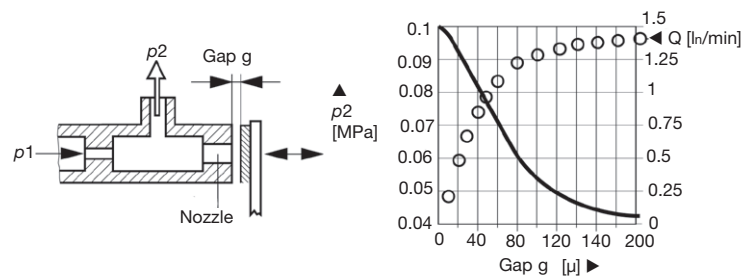

Fig. 2.12: Principle and pressure curve of a nozzle/flapper system

.....
3. Vacuum technology

The compact dimensions (72.9 x 52.5 x 9.9 mm) and low weight (approx. 50 g) of vacuum generator units allow them to be installed close to the consumer (suction cup).

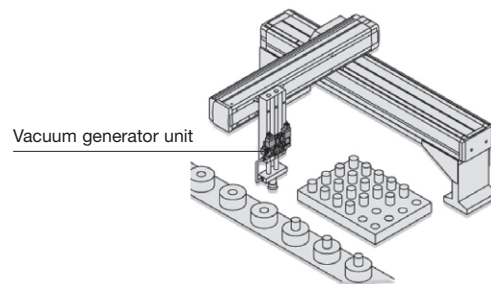

Fig. 3.16: Application example with a vacuum unit

Low pressure drop is important

3.2.5 Vacuum filters

Vacuum filters are used to clean the air sucked in by the suction cup. They prevent foreign bodies and liquids from entering the ejector and the unit's operational reliability from being impaired. When selecting vacuum filters, attention must be paid to ensuring that the flow resistance is as low as possible (in contrast to overpressure filters).



Fig. 3.17: Vacuum filters for different levels of suction power

4. Link between pneumatics and electronics

139

There are many connection options here too. A basic knowledge of electrical engineering is required in order to understand them all. In addition to taking the voltage and current into account, attention must also be paid to the internal resistance (R_i) of the sensors. If this is too large or two to three PLCs are connected to the sensor in series, the sum of all resistances may be too large and it will no longer be measured correctly.

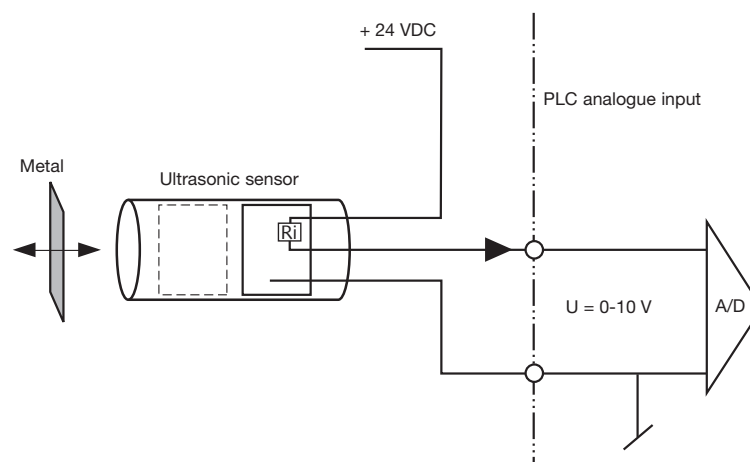

Fig. 4.7: Analogue sensor (ultrasonic) connected to PLC

0 to 10 V
Voltage (unipolar)

The simplest of all analogue measurement signals is "unipolar" voltage. It ranges from 0 to 10 V. The signal can be recorded directly with a measuring instrument. No negative voltages must arise. The voltage measurement signal is however very susceptible to faults, as electromagnetic coupling means that it cannot be used. Only shielded cables should therefore be used. In addition, these signals are only suited to short distances, as long lines result in a drop in voltage, which in turn distorts the measurement result. This measurement signal is therefore not suitable for industrial applications.

-10 V to +10 V
Voltage (bipolar)

It goes without saying that simple measurement signals are no longer sufficient for controlling engines. The analogue range has been extended from -10 V to +10 V. This means that -10 V to 0 V can, for example, be used for anticlockwise rotation from 0 to 100%, and the positive range from 0 to +10 V can be used for the clockwise direction.